

Solar Creek

100–110 Watt MONO-FACIAL MODULE

- IEC61215: 2021
- IEC61730: 2016
- TUV Rheinland Standard
- Lloyd'S Ariel Re Solar Performance Insurance
- ISO9001: 2015 Quality Management System
- ISO14001: Environmental Management System
- CE: Europe Standard
- Inmetro Certificate
- ETL Certificate

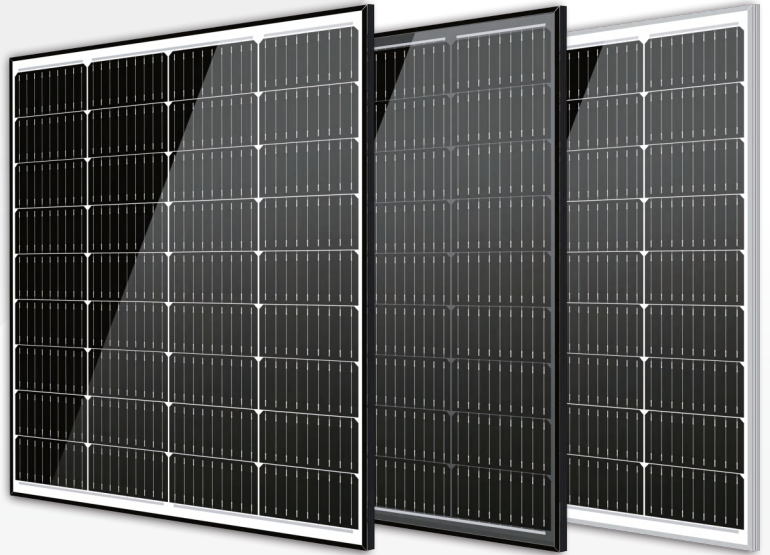

KEY FEATURES



5BB/MBB
More uniform current collection capability, reducing the current heat loss of the internal cells.



Low Light Features
Higher performance under low light environment.



Higher Output Power
The output power of 36 half-cells Monocrystalline modules is up to 110W.



PID Protection
Ensure the attenuation probability caused by PID phenomenon is minimized.



Harsh Environmental Adaptability
Strict salt spray and ammonia corrosion test by the third party.



Load Capacity
Mechanical load tests including wind load 2400 Pa and snow load 5400 Pa.

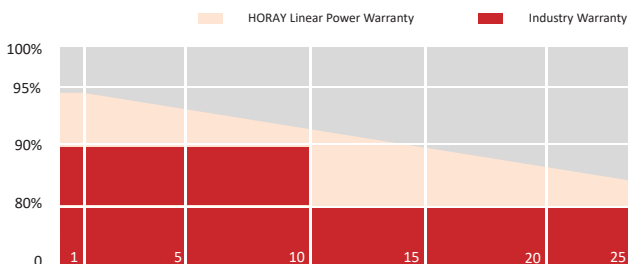

MECHANICAL DIAGRAMS

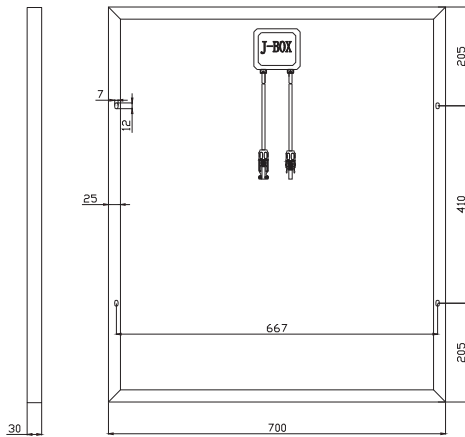

SPECIFICATIONS

Weight	6.9kg
Dimension	820mm*700mm*30mm
Cell Dimension	166*83mm
Cell Amount	4*9 pcs
Maximum System Voltage	1500V
Junction Box	IP67
Frame	Aluminum Alloy
Cable	Length can be customized
Connector	MC4 compatible
Application Level	Class A

ELECTRICAL PARAMETERS AT STC

Module Type	HS100-MHL	HS105-MHL	HS110-MHL
Power	100W	105W	110W
Open Circuit Voltage	25.10V	25.20V	25.32V
Short Circuit Current	5.08A	5.30A	5.53A
Maximum Power Voltage	20.90V	21.00V	21.10V
Maximum Power Current	4.79A	5.00A	5.21A
Module Efficiency	17.42%	18.29%	19.16%

* Under Standard Test Conditions (STC) of irradiance of 1000 W/ m², spectrum AM 1.5 and cell temperature of 25°C.

ELECTRICAL PARAMETERS AT NMOT

Power	76W	80W	84W
Open Circuit Voltage	23.81V	24.00V	24.17V
Short Circuit Current	4.06A	4.24A	4.42A
Maximum Power Voltage	19.84V	20.00V	20.14V
Maximum Power Current	3.83A	4.00A	4.17A
Module Efficiency	13.24%	13.94%	14.63%

* Under Nominal Module Operating Temperature (NMOT), irradiance of 800 W/ m², spectrum AM 1.5, ambient temperature 20°C, wind speed 1 m/s.

TEMPERATURE CHARACTERISTICS

NMOT	45±2°C	Temp Coefficient of ISC	+0.05%/°C
Temp Coefficient of VOC	-0.28%/°C	Temp Coefficient of Pmax	-0.34%/°C

IV CHARACTERISTICS

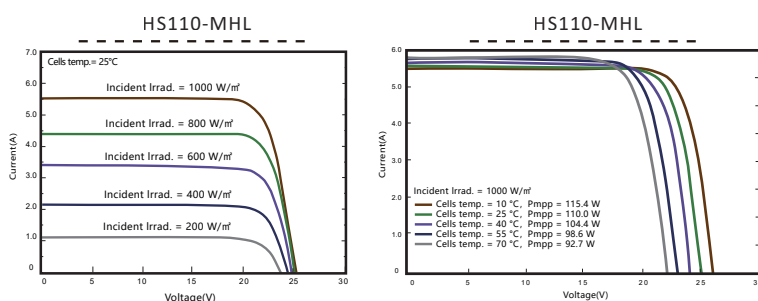

MAXIMUM RATING

Power selection	0~+5W
Measuring uncertainty of Pm	0~±3%
Operating Temperature	-40°C~+85°C
Wind Load/Snow Load	2400pa/5400pa
Fuse Current	15A

5 YEARS Quality Warranty

25 YEARS Power Warranty

CAUTION: READ SAFETY AND INSTALLATION INSTRUCTIONS BEFORE USING THE PRODUCT.

©2024 Horay Solar Co.,Ltd. All rights reserved. Specifications included in this datasheet are subject to change without notice.

This type is a custom solar module. Please confirm with HORAY SOLAR before ordering.

Version number: MHO_EN_2024_A