

Solar Creek

80–90 Watt MONO-FACIAL MODULE

- IEC61215: 2021
- IEC61730: 2016
- TUV Rheinland Standard
- Lloyd'S Ariel Re
- Solar Performance Insurance
- ISO9001: 2015
- Quality Management System
- ISO14001:
- Environmental Management System
- CE: Europe Standard
- Inmetro Certificate
- ETL Certificate

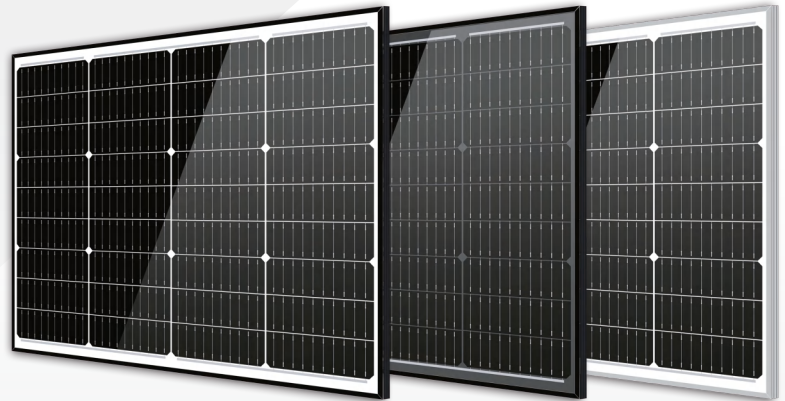

KEY FEATURES



SBB/MBB
More uniform current collection capability, reducing the current heat loss of the internal cells.



Low Light Features
Higher performance under low light environment.



Higher Output Power
The output power of 36 half-cells Monocrystalline modules is up to 90W.



PID Protection
Ensure the attenuation probability caused by PID phenomenon is minimized.



Harsh Environmental Adaptability
Strict salt spray and ammonia corrosion test by the third party.



Load Capacity
Mechanical load tests including wind load 2400 Pa and snow load 5400 Pa.

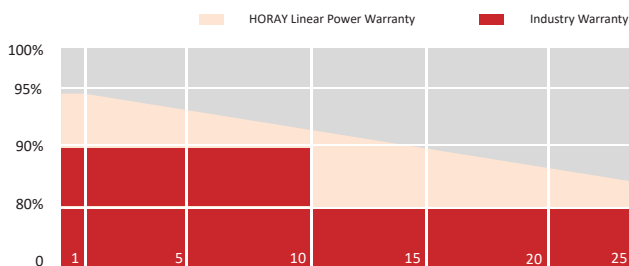

HEADQUARTER: HORAY SOLAR CO., LTD.

GLOBAL MARKETING AND SERVICE: HORAY SOLAR GMBH

✉ sales@horaysolar.com 🌐 www.horaysolar.com ☎ +86-510 83580688
📍 NO.30-5, East Yanxin Road, Huishan District, Wuxi 214177 Jiangsu P.R China

✉ info@horaysolar.com 🌐 www.horaysolar.com
📍 Robert-Bosch-Str. 29, Langen, Frankfurt am Main, Germany

MECHANICAL DIAGRAMS

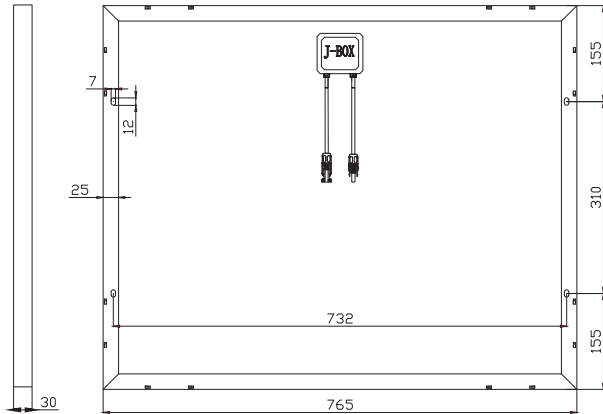

SPECIFICATIONS

Weight	5.7kg
Dimension	620mm*765mm*30mm
Cell Dimension	182*60.7mm
Cell Amount	4*9 pcs
Maximum System Voltage	1500V
Junction Box	IP67
Frame	Aluminum Alloy
Cable	Length can be customized
Connector	MC4 compatible
Application Level	Class A

ELECTRICAL PARAMETERS AT STC

Module Type	HS80-MHO	HS85-MHO	HS90-MHO
Power	80W	85W	90W
Open Circuit Voltage	25.10V	25.56V	25.68V
Short Circuit Current	4.01A	4.23A	4.46A
Maximum Power Voltage	21.20V	21.30V	21.40V
Maximum Power Current	3.78A	3.99A	4.21A
Module Efficiency	16.87%	17.92%	18.98%

* Under Standard Test Conditions (STC) of irradiance of 1000 W/m², spectrum AM 1.5 and cell temperature of 25°C.

ELECTRICAL PARAMETERS AT NMOT

Power	60W	64W	68W
Open Circuit Voltage	23.84V	24.07V	24.29V
Short Circuit Current	3.20A	3.38A	3.56A
Maximum Power Voltage	19.87V	20.06V	20.24V
Maximum Power Current	3.02A	3.19A	3.36A
Module Efficiency	12.65%	13.49%	14.34%

* Under Nominal Module Operating Temperature (NMOT), irradiance of 800 W/m², spectrum AM 1.5, ambient temperature 20°C, wind speed 1 m/s.

TEMPERATURE CHARACTERISTICS

NMOT	45±2°C	Temp Coefficient of ISC	+0.05%/°C
Temp Coefficient of VOC	-0.28%/°C	Temp Coefficient of Pmax	-0.34%/°C

IV CHARACTERISTICS

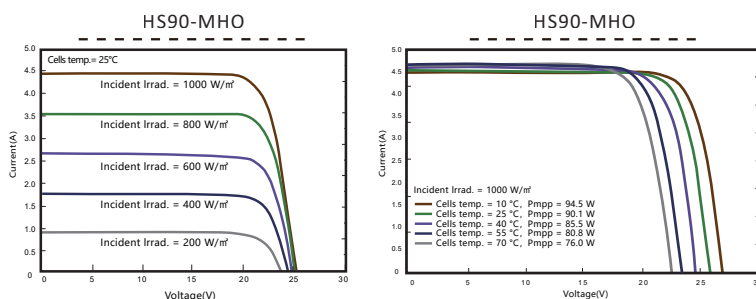

MAXIMUM RATING

Power selection	0~+5W
Measuring uncertainty of Pm	0~±3%
Operating Temperature	-40°C~+85°C
Wind Load/Snow Load	2400pa/5400pa
Fuse Current	15A

5 YEARS Quality Warranty

25 YEARS Power Warranty

CAUTION: READ SAFETY AND INSTALLATION INSTRUCTIONS BEFORE USING THE PRODUCT.

©2024 Horay Solar Co.,Ltd. All rights reserved. Specifications included in this datasheet are subject to change without notice.

This type is a custom solar module. Please confirm with HORAY SOLAR before ordering.

Version number: MHO_EN_2024_A